



**AGENDA**  
**DRAINAGE DISTRICT**  
**BOARD OF DIRECTORS**  
**September 1, 2015**  
**10:00 A.M.**

**NOTICE is hereby given in accordance with Chapter 551, Texas Government Code, that a SPECIAL MEETING of the Drainage District #1 Board of Directors will be held in the Commissioners Courtroom of the Administration Building, 100 E. Cano, 1st floor, Edinburg, Hidalgo County, Texas. Discussion and possible action relating to the following business will be transacted:**

1. **Roll Call**
2. **Prayer**
3. **Open Forum**
4. **Approval of Consent Agenda**
5. Discussion on Hidalgo County Drainage District No. 1 Drainage projects, maintenance and operations
6. **AI -51143** Public Hearing to discuss proposed 2015 Tax Rate.
7. **AI -51078** Discussing, acceptance and action in connection with proposed Amendment #2 to the existing Letter of Engagement with Hon. Michael Lee, Lee Law Firm for: Further Investigations into Conflicts of Interest by and through, the District Manager, Integ Corporation [Godfrey Garza, Jr., President] which were part of the Scope of Services for Amendment 1.
8. **AI -51076** A. Requesting approval to purchase four (4) new Caterpillar CT660 Dump Trucks from Holt Truck Centers through the District's Membership with BuyBoard Contract No. 430-13 to include Extended Service Coverage and BuyBoard fees in the total amount of \$581,225.64.  
B. Request approval of a Budget Amendment from the District's un-reserve General fund balance in the amount \$581,225.64 for the purchase of the above mention Dump Trucks.

9. **AI -51136** 2012 Bond Referendum Project
- A. Approval of offer letter of acceptance and closing documents as it relates to parcel 8, lot 35, Seminole Valley Subdivision Alamo.
  - B. Approval of manual check to be issued for the completion of the acquisition transaction.
10. **AI -51091 2013 BOND SERIES**
- A.) Requesting approval of final negotiated Professional Agreement with Javier Hinojosa Engineering for the provision of Engineering Services as it relates to Pct. 2 - PSJA Lateral Drain Ditch. Approved for negotiations by HCDD1 Board of Directors on April 28, 2015.
  - B.) Pursuant to the Boards approval of Professional Agreement with Javier Hinojosa Engineering requesting approval of Work Authorization No. 1 in the amount of \$135,000.00 for Engineering Services as it relates to Pct. 2 - PSJA Lateral Drain Ditch.
  - C.) Pursuant to the Boards approval of Professional Agreement with Javier Hinojosa Engineering; requesting approval of Work Authorization No. 2 in the amount of \$36,000 for Survey Services as it relates to Pct. 2 - PSJA Lateral Drain Ditch.
11. **AI -51139 2013 BOND SERIES**
- Requesting approval of Notice to Suspend Work for Construction Contract No. HCDD1-14-028-10-28 "Drain Control Structures - Monte Cristo & Weslaco North Lateral". Contractor: M-5 Texas Enterprises, LLC.
12. **AI -51154**
- A. Request acceptance and approval by the Hidalgo County Drainage District No. 1 Board of Directors of an "Order" authorizing the Purchase of certain personal property (as described in attachments herein) from Hidalgo County Pct.3 for the agreed upon book value.
  - B. Request approval of a Budget Amendment from District's un-reserve General Fund in the amount of \$220,393.94 for the purchase of equipment from Hidalgo County Pct.3.
13. **Closed Session:**
- Board of Directors may go into Closed Session pursuant to Chapter 551, Texas Government Code, Sections 551.071 & 551.072 to discuss the following:
- A. **Real Estate Acquisition**
  - B. **Pending and/or Potential Litigation**

14. **Open Session:**
  - A. **Real Estate Acquisition**
  - B. **Pending and/or Potential Litigation**
15. **Closed Session:**

Board of Directors may reconvene into Closed Session for the discussion regarding the agenda items listed
16. **Open Session:**

Board of Directors may reconvene into Open Session for the discussion regarding the agenda items listed
17. **Adjourn**

**AI -51143**

**6.**

**DRAINAGE DISTRICT**

Meeting Date: 09/01/2015

Submitted By: Monica Badillo,  
EXECUTIVE OFFICE

Department: EXECUTIVE OFFICE

---

Information

CAPTION

Public Hearing to discuss proposed 2015 Tax Rate.

BACKGROUND

---

Fiscal Impact

Attachments

NOTICE

---

**Form Review**

<b>Inbox</b>	<b>Reviewed By</b>	<b>Date</b>
Budget & Management	Veronica Ortiz	08/28/2015 04:24 PM
Final Approval	Monica Badillo	08/28/2015 04:56 PM
Form Started By: Monica Badillo		Started On: 08/28/2015 02:58 PM
Final Approval Date: 08/28/2015		

# Notice of Public Hearing on Tax Increase

The HIDALGO COUNTY DRAINAGE DISTRICT #1 will hold two public hearings on a proposal to increase total tax revenues from properties on the tax roll in the preceding tax year by 3.82 percent (percentage by which proposed tax rate exceeds lower of rollback tax rate or effective tax calculated under Chapter 26, Tax Code). Your individual taxes may increase at a greater or lesser rate, or even decrease, depending on the change in the taxable value of your property in relation to the change in taxable value of all other property and the tax rate that is adopted.

The first public hearing will be held on September 1, 2015 at 10:00AM at Hidalgo County Commissioner's Courtroom of the Admin. Bldg, 100 E. Cano, 1st floor, Edinburg, Texas.

The second public hearing will be held on September 15, 2015 at 9:00AM at Hidalgo County Commissioner's Courtroom of the Admin Bldg, 100 E. Cano, 1st floor, Edinburg, Texas.

The members of the governing body voted on the proposal to consider the tax increase as follows:

**FOR:** Hidalgo County Judge, Ramon Garcia Hidalgo Co. Comm, A C Cuellar  
Hidalgo Co. Comm, Joseph Palacios Hidalgo Co. Comm, Joe Flores  
Hidalgo Co. Comm, Eduardo (Eddie)  
Cantu

**AGAINST:**

**PRESENT** and not voting:

**ABSENT:**

The average taxable value of a residence homestead in HIDALGO COUNTY DRAINAGE DISTRICT #1 last year was \$88,191. Based on last year's tax rate of \$0.0957 per \$100 of taxable value, the amount of taxes imposed last year on the average home was \$84.40.

The average taxable value of a residence homestead in HIDALGO COUNTY DRAINAGE DISTRICT #1 this year is \$94,877. If the governing body adopts the effective tax rate for this year of \$0.0916 per \$100 of taxable value, the amount of taxes imposed this year on the average home would be \$86.91.

If the governing body adopts the proposed tax rate of \$0.0951 per \$100 of taxable value, the amount of taxes imposed this year on the average home would be \$90.23.

Members of the public are encouraged to attend the hearings and express their views.

**AI -51078**

7.

**DRAINAGE DISTRICT**

Meeting Date: 09/01/2015

Submitted For: Marty Salazar

Submitted By: Marty Salazar,  
PURCHASING DEPT.

Department: PURCHASING DEPT.

---

Information

CAPTION

Discussing, acceptance and action in connection with proposed Amendment #2 to the existing Letter of Engagement with Hon. Michael Lee, Lee Law Firm for: Further Investigations into Conflicts of Interest by and through, the District Manager, Integ Corporation [Godfrey Garza, Jr., President] which were part of the Scope of Services for Amendment 1.

BACKGROUND

---

Fiscal Impact

FISCAL YEAR:

ACCOUNT #:

FUNDS AVAILABLE? Y/N:

MATCHING FUNDS? Y/N:

BUDGETARY IMPACT:

Minimum cost of Amendment #2 would expenditure is approximately \$30K.

---

Attachments

Second Amendment/Letter

---

Form Review

<b>Inbox</b>	<b>Reviewed By</b>	<b>Date</b>
Budget & Management	Veronica Ortiz	08/26/2015 02:46 PM
Final Approval	Monica Badillo	08/26/2015 02:54 PM
Purchasing Department	Marty Salazar	08/28/2015 04:36 PM
Form Started By: Marty Salazar		Started On: 08/26/2015 02:29 PM
Final Approval Date: 08/28/2015		

615 N UPPER BROADWAY, SUITE 708  
CORPUS CHRISTI, TEXAS 78401-0732  
TELEPHONE: 361/882-4444

126 W MAIN, SUITE B  
KENEDY, TEXAS 78119  
TELEPHONE: 830/583-0899

## THE LEE FIRM

A PROFESSIONAL CORPORATION  
ATTORNEYS AT LAW

TOLL FREE: 800/580-4444  
FAX: 361/882-7844  
EMAIL: LEELAW@THELEEFIRM.COM

MICHAEL S LEE  
BOARD CERTIFIED  
PERSONAL INJURY TRIAL LAW  
TEXAS BOARD OF LEGAL SPECIALIZATION

### REPLY TO CORPUS CHRISTI ADDRESS

August 28, 2015

Via E-mail – [martha.salazar@co.hidalgo.tx.us](mailto:martha.salazar@co.hidalgo.tx.us)

Martha Salazar  
Hidalgo County Purchasing Department  
2812 S. Business Hwy. 281  
Edinburg, Texas 78539

Re: HCDD1-14-140-06-004-VYG  
Professional Legal Services - Review and Report-Agreement between Hidalgo County  
Drainage District No.1 and Integ Corp.

Dear Ms. Salazar:

Attached please find the “Second Amended Letter of Engagement for Legal Services”.

Yours very truly,



Michael S. Lee

MSL/cm  
Enclosure

cc: Evangelina Garcia  
Via E-mail – [evangelina.garcia@co.hidalgo.tx.us](mailto:evangelina.garcia@co.hidalgo.tx.us)

**SECOND AMENDED LETTER OF ENGAGEMENT FOR LEGAL SERVICES**

**RFQ No: HCDD1-14-140-06-04-VYG**

**Professional Legal Service in connection with the review and report for the agreement between Hidalgo County Drainage District No. 1 and Integ Corporation**

This Agreement is made by and between Michael S. Lee/The Lee Firm, A Professional Corporation (“Attorney”), and Hidalgo County Drainage District No. 1 (“Client”) to review and report for the agreement between Hidalgo County Drainage District No. 1 and Integ Corporation.

1. Scope of Services.

A. Contract Analysis.

The Attorney will provide legal services as requested by Client and accepted by Attorney on a case-by-case and matter-by-matter assignment. Attorney shall provide those legal services reasonably required to represent Client, and shall keep Client informed of the progress of the case or matter. In order to enable Attorney to render effective legal services, Client shall provide all facts and keep Attorney informed of all developments relating to the matter. Attorney must rely on the accuracy and completeness of the facts and information provided by Client. In addition, Attorney will provide legal services in reviewing all documents related to the contractual issues between Hidalgo County Drainage District No. 1 and Integ Corporation; review appropriate Texas case law, whether statutory and/or common law; conferences and meetings with Hidalgo County Drainage District No. 1 representatives; interviews and conferences with any subcontractors and/or other contractors involved in the project developments that are the subject of the issues between Hidalgo County Drainage District No. 1 and Integ Corporation; interview witnesses; provide appropriate legal opinions relating to same. **Due Date: On or Before May 19, 2015.**

B. Investigation/Conflict of Interest.

In 2014 the Hidalgo County Drainage District (District) retained The Lee Firm, A Professional Corporation (The Lee Firm) to investigate and evaluate the contract that was entered into between Integ Corporation (Integ) and the District as it related to compensation paid to Integ, related to the Hidalgo County Master Drainage System Phase II and the federal Border Infrastructure Improvement Project. Currently, The Lee Firm has been working within that scope guidelines. However, the District wishes to amend the scope of the contract between itself and The Lee Firm. The District requests The Lee Firm to expand the scope of its professional evaluation and to analyze any potential conflicts of interests related to Integ, Godfrey Garza and the District as well as contractors who had contracted with the District. As a result, the District authorizes The Lee Firm to file a Petition to Investigate under Texas Rule of Civil Procedure 202 in order to request a Presiding Judge that the District be allowed to take depositions under oath and gather facts and evidence through such discovery in order to determine whether or not there are in fact potential conflicts. The District requests The Lee Firm to investigate any potential conflicts of interest involving any contract or subcontracts related to both the District, more specifically Hidalgo County Master Drainage System Phase II, as well as the federal Border Infrastructure Improvement Project. If the Presiding Judge will allow such investigate discovery to proceed forward, The Lee Firm will do such and will provide the District with any analysis of any conflicts of interest revealed by its discovery and investigation. **Due Date: On or Before August 15, 2015.**

C. Further Investigation of Conflicts of Interest.

Preparation and filing of the Petition to Investigate Under Rule 202. If this legal relief is granted by the Presiding Judge, then oral/videotaped depositions will be scheduled and sworn

testimony will be obtained along with the identification and explanation of various documents relating to same. This process will allow HCDD to understand what conflicts exist, why such conflicts became conflicts, and why was there not disclosure of such conflicts per contractual agreements by and through the District Manager, Integ Corporation (Godfrey Garza, Jr.- President). This process and the information gathered therefrom, if granted by the Presiding Judge, will aid The Lee Firm in analyzing more specifically possible conflicts of interest and reaching legal conclusions regarding such. After thorough investigation and analysis, The Lee Firm will present a final report of its findings to HCDD along with all official testimony transcripts. The Petition to Investigate Under Rule 202 would be directed to the following persons and entities:

1. Integ Corporation – 4209 Mile 8 Rd., Edinburg, TX 78541  
Phone: 956-227-3630

Godfrey Garza, Jr. – Owner

2. Valley Data Collection Specialists, Inc. – 4121 N. 23<sup>rd</sup> St., McAllen, TX 78504  
Phone: 956-687-4434

Godfrey Garza III – Former Director

Jonathan Garza – Former Director

Annie Q. Garza – President and Director

**Due Date: Three to Six Months from the date of execution of this Second Amended Letter of Engagement for Legal Services, subject to the ruling of the Presiding Judge of the District Court**

2. Fees. Hourly fees for legal services are based on the amount of time each lawyer or paralegal spends working on the Client’s behalf multiplied by their respective hourly rate. Hourly rates vary among professionals depending on experience, level of expertise and market conditions. Hourly rates are reviewed annually and will be adjusted only with the Client’s written consent. The fee structure accepted for this matter is stated in the attached Exhibit “A”. Lead counsel and all attorneys and legal staff working on the assigned matter shall be identified in the attached fee structure. Estimated fees will be a minimum of \$25,000.00.
3. Expenses. By engaging services from Attorney, Client authorizes third-party contracting necessary for representation on Client’s behalf and such costs shall be reimbursed for actual costs as incurred as per schedule of costs attached as Exhibit “A”, although this list may not be all inclusive. The Attorney will seek approval from Client for any individual expenses that are expected to exceed the sum of \$500.00. Attorney shall also obtain Client’s consent before retaining an outside investigator, consultant or expert witness. Estimated expenses will be a minimum of \$5,000.00.
4. Billing. The Client shall be billed monthly for fees, costs and expenses incurred (detailed in the attached Exhibit “A”) and will reimburse firm for actual expenses incurred in connection with litigation. The Client shall also pay for the time the Attorney spends traveling, (when necessary). Hourly and/or timed billing shall be submitted in increments of one-tenth (1/10th) of an hour. No block billing shall be accepted. Each billing entry shall separately itemize the activity or task performed and the amount of corresponding time. All billing invoices are subject to review by the County Auditor as provided for under the Texas Local Government Code. Payment of billing invoices requires approval by the Hidalgo County Drainage District No. 1.

5. Termination. This agreement will terminate once the case or matter assigned is completely resolved/dismitted, or in the event the Client chooses to terminate the agreement in advance of completion, resolution or final dismissal of the matter, then upon written notice of termination. The term of service of the original Letter of Engagement for Legal Services commenced on October 13, 2014 and expires on February 20, 2015. The term of service was extended by the First Amended Letter of Engagement for Legal Services to August 15, 2015. Due to the new requested further investigation, Attorney requests an extension which results in the expiration date being three to six months from the date of execution of this Second Amended Letter of Engagement for Legal Services, subject to the rulings of the Presiding Judge of the District Court.
6. Client approval is necessary for settlement. Attorney is authorized to engage in settlement negotiations if and when appropriate in their professional judgment. No settlement of any nature shall be made for any of the claims or causes of action of Client without the complete approval of Client. Upon Client approval, Attorney shall have full authority to sign papers or documents regarding settlement. This provision is subject to the terms and conditions of the policy of insurance that indemnifies Client for the claims in the above matter.
7. The Hidalgo County Drainage District No. 1 accepts and approves of Attorney's Professional Liability Insurance with the limits of \$500,000.00.
8. Entire Agreement. This Agreement contains the entire understanding and agreement between the parties with respect to its subject matter (*i.e.*, the review and report for the agreement between Hidalgo County Drainage District No. 1 and Integ Corporation) and supersedes any prior or contemporaneous written or oral agreements, representations or warranties between the parties herein.
9. Amendment. This Agreement may be amended only by written amendment with the approval of the Hidalgo County Drainage District No. 1 and their duly authorized agent or representative.
10. Governing Law. This Agreement shall be construed in accordance with the laws of the State of Texas which law shall govern any actions arising hereunder. Any dispute arising hereunder shall be brought before a court of competent jurisdiction in Hidalgo County, Texas.

AGREED:

LAW FIRM:

The Lee Firm, A Professional Corporation

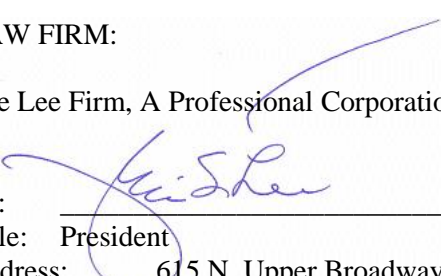
By:  \_\_\_\_\_  
 Title: President  
 Address: 615 N. Upper Broadway, Suite 708  
 Corpus Christi, Texas 78401  
 Telephone: 361.882.4444  
 Fax: 361.882.7844  
 E-mail: [theleefirmpc@theleefirm.com](mailto:theleefirmpc@theleefirm.com)

Date: August 28, 2015

HIDALGO COUNTY DRAINAGE  
 DISTRICT NO. 1

By: \_\_\_\_\_  
 Title: \_\_\_\_\_  
 Address: 2812 S. Business Hwy 281  
 Edinburg, Texas 78539

**Exhibit "A"**  
**SCHEDULE OF COSTS IN CONNECTION WITH LEGAL REPRESENTATION  
 INVOLVING HIDALGO COUNTY DRAINAGE DISTRICT NO. 1  
 AND INTGEG CORPORATION**

**Attorney Fees:**                    **Hourly Rate:**  
 Attorneys:                            See Attached  
 Legal Assistant:                    See Attached

**Legal Fees/Court Costs:**

Filing Fees	Actual costs
Service of Process & Subpoenas	Actual costs
Mediation Fees	Actual costs
Legal Research Expenses	Actual costs (Lexis Nexis)
Depositions (Court Reporter & Video as appropriate)	Actual costs
Internet Search Fees	Actual costs
Witness Fees	Actual required by law
Expert Witness Fees	Actual costs
Hearing Transcript Fees (as appropriate)	Actual costs
Investigator Fees (as appropriate)	Actual costs

**Travel Expenses:**

Mileage Rate (IRS guidelines recommended) – Prevailing IRS Rate  
 Air Travel (most economical travel recommended) – Most economical taking into consideration travel time.  
 Hotel (most economical recommended – not to exceed \$100.00 per day)  
 Meals (to be reimbursed only if traveling out of town – not to exceed \$39.00 per day)

**Office Expense:**

Faxes	\$1.25 per page
Copies	\$ .30 per page
Binding	As charged by Texas Star Documents
Telephone (Long Distance only)	As charged by Foremost

**Postage and Express Mail:**

U.S. Mail	Actual costs
Express Mail	Actual costs
Other:	
Overnight Delivery	Actual costs

**Itemized receipts must be provided for each expense.**

Send billing to: Hidalgo County Drainage District No. 1  
 ATTN: Evangelina Garcia  
 Hidalgo County Purchasing Department  
 2812 S. Business Hwy. 281  
 Edinburg, Texas 78539  
 E-mail: Evangelina.garcia@co.hidalgo.tx.us

**CHARGES FOR ATTORNEY FEES AND LEGAL ASSISTANT**

Michael S. Lee Senior Attorney	\$250.00 per hour
Contract Senior Attorney/Of Counsel	\$250.00 per hour
Contract Junior Attorney/Of Counsel	\$200.00 per hour
Senior Paralegal	\$125.00 per hour
Junior Paralegal	\$100.00 per hour
Investigator	\$100.00 per hour
Administrative Tasks	\$75.00 per hour

**AI -51076**

**8.**

**DRAINAGE DISTRICT**

Meeting Date: 09/01/2015

Submitted For: Jaime Salazar

Submitted By: Jaime Salazar, DRAINAGE  
DISTRICT

Department: DRAINAGE DISTRICT

---

Information

CAPTION

A. Requesting approval to purchase four (4) new Caterpillar CT660 Dump Trucks from Holt Truck Centers through the District's Membership with BuyBoard Contract No. 430-13 to include Extended Service Coverage and BuyBoard fees in the total amount of \$581,225.64.

B. Request approval of a Budget Amendment from the District's un-reserve General fund balance in the amount \$581,225.64 for the purchase of the above mention Dump Trucks.

BACKGROUND

---

Fiscal Impact

Attachments

Holt Trucks

---

**Form Review**

<b>Inbox</b>	<b>Reviewed By</b>	<b>Date</b>
Budget & Management	Veronica Ortiz	08/26/2015 02:32 PM
Final Approval	Monica Badillo	08/28/2015 04:56 PM
Form Started By: Jaime Salazar		Started On: 08/26/2015 01:50 PM
Final Approval Date: 08/28/2015		



CUSTOMER PROPOSAL

Customer Number:	562700	Date:	8/18/2015
Customer Name:	Hidalgo County Drainage District	Proposal good through:	10/17/2015
<b>Description:</b>	<b>BUY BOARD CONTRAC # 430.13</b>		<b>Dump</b>
	<b>Truck with Caterpillar CX31 Automatic Transmission</b>		
Address:	602 North Doolittle	Sales Representative	
City, State, Zip:	Edinburg, TX 78541	Mark Brunnemann - (956) 289-7636	
Contact Name:	Jaime Salazar	Registration Class:	
Contact Phone #:	956-292-7087	NONE - Buyer will register unit	
Contact E-mail:	jaime.salazar@hcdd1.org	Requested G.V.W.R.	
		As per MSO or Title; no change	

Stock/ID Number:	TBD	Make:	Caterpillar
VIN:	TBD	Model:	CT660
To be delivered on or about:	14 to 16 weeks from PO	Year:	2016
Freight on Board (F.O.B.):	HOLT TRUCK CENTER - Edinburg, TX		

	Per Unit	Total
Buy Board Base Price	\$105,098.61	\$420,382.44
Additional Vehicle and Accessories Description:	See Notes Below	See Notes Below
Optional Adds	\$17,271.09	\$69,080.36
Ox- Maverick 15' Dump Body	\$15,147.11	\$60,588.44
	\$0.00	\$0.00
	\$0.00	\$0.00
<b>NET Sales Price</b>	<b>\$137,516.81</b>	<b>\$550,067.24</b>
TRADE-IN ALLOWANCE	\$0.00	\$0.00
<b>Total Net Sales without Tax</b>	<b>\$137,516.81</b>	<b>\$550,067.24</b>
BALANCE OWED ON TRADE-IN	\$0.00	\$0.00
DOWN PAYMENT	\$0.00	\$0.00
FET - FEDERAL EXCISE TAX	\$0.00	\$0.00
FET - FEDERAL EXCISE TAX - BODY	\$0.00	\$0.00
LSC - STATE MOTOR VEHICLE SALES TAX	\$0.00	\$0.00
PST - 1% TERP TAX (1997 & NEWER)	\$0.00	\$0.00
TTL - TITLE & REGISTRATION	\$0.00	\$0.00
VIT - VEHICLE INVENTORY TAX	\$0.00	\$0.00
ESC - Extended Service Coverage GOLD 60 months/100,000 miles/10,000 hours, which ever	\$7,789.60	\$31,158.40
Out of State Vehicle Fee	\$0.00	\$0.00
<b>Sales Price:</b>	<b>\$145,306.41</b>	

Quantity:	4
-----------	---

**Total Sales Price: \$ 581,225.64**

Additional Vehicle and Accessories Description:



CUSTOMER PROPOSAL

Customer Number:	562700	Date:	8/18/2015
Customer Name:	Hidalgo County Drainage District I	Proposal good through:	10/17/2015
<b>Description:</b>	<b>BUY BOARD CONTRAC # 430.13</b>		<b>Dump</b>
	<b>Truck with Caterpillar CX31 Automatic Transmission</b>		

GOLD ESC+ 60 months/100,000 miles/10,000 hours

**Special Titling & Registration Notes:**  
None

**Lienholder Notes:**  
None

**TRADE-IN NOTES**  
None

**DISCLAIMER:**  
Any order based on this Proposal subject to Customer executing Dealer's standard for Retail Purchase Order Incorporating above terms. Any documentary fees, state tax, title registration and license fees subject to adjustment and change. Actual F.E.T. to be paid by Dealer, subject to adjustment. Any F.E.T. variance will be responsibility of Dealer. Manufacturer has reserved the right to change the price to Dealer of any vehicle not currently in Dealer's stock, without notice to Dealer. If Quoted Vehicle's not currently in Dealers stock, Dealer reserves right to change Quotation Total to reflect any price increases from Manufacturer. This Proposal is based upon Dealer's current and expected inventory, which is subject to change. Dealer is not obligated to retain any specific vehicles in stock or maintain any specific inventory level. Dealer shall not be obligated to fulfill Proposal in event quoted vehicle's not in stock or available within requested delivery schedule at time Proposal accepted. Dealer shall not be liable for any delay in providing or inability to provide Quoted Vehicle's, where such inability or delay is due, in whole or in part, to any cause beyond the reasonable control of Dealer or is without the gross negligence or intended misconduct of Dealer. Above listed Trade Value based upon current appraisal of Trade Vehicle's. Dealer may adjust Trade Value of Trade Vehicle's to reflect changes in condition and/or mileage of Trade Vehicle's between date of current appraisal and acceptance of this Proposal by Customer.

**SELLER:** **BUYER:**

  
Signature

Mark Brunnemann

Printed Name:

Sales Representative

Title:

Signature

Printed Name:

Title:



CUSTOMER PROPOSAL

Customer Number:	562700	Date:	8/18/2015
Customer Name:	Hidalgo County Drainage District !	Proposal good through:	10/17/2015
Description:	<b>BUY BOARD CONTRAC # 430.13</b> <span style="float: right;"><b>Dump</b></span> <b>Truck with Caterpillar CX31 Automatic Transmission</b>		
8/18/2015			
Date:		Date:	

Thank you for the opportunity to earn your business. We look forward to working with you on your business needs.



# **CT660S SBA 6x4**

Sales Proposal For:

**HCD Dist 1 - Cat CX31 AUTOMATIC**

Presented By:

**HOLT TEXAS LTD.**



Prepared For:  
HCD Dist 1 - Cat CX31 AUTOMATIC

Reference ID: N/A

Presented By:  
HOLT TEXAS LTD.  
Mark Brunnemann  
3302 S W W WHITE RD  
SAN ANTONIO TX 78222 - 4843  
(210)648-8343

We are pleased to have the opportunity to offer the following proposal for the application you requested.

**Model Profile**  
**2016 CT660S SBA 6x4 (CF7AA)**

<b>APPLICATION:</b>	Light Aggregate
<b>MISSION:</b>	Requested GVWR: 54600. Calc. GVWR: 54600 Calc. Start / Grade Ability: 27.67% / 1.74% @ 55 MPH Calc. Geared Speed: 96.3 MPH
<b>DIMENSION:</b>	Wheelbase: 187.00, CA: 125.00, Axle to Frame: 69.00
<b>ENGINE, DIESEL:</b>	{CT 13} EPA 2010, SCR, 370 HP @ 1700 RPM, 1350 lb-ft Torque @ 1000 RPM, 2100 RPM Governed Speed, 370 Peak HP (Max)
<b>TRANSMISSION, AUTOMATIC:</b>	{Caterpillar CX31} 1st Generation Controls; 6 Speed, Includes Oil Level Sensor, with PTO Provision, for ON/OFF Highway
<b>CLUTCH:</b>	Omit Item (Clutch & Control)
<b>AXLE, FRONT NON-DRIVING:</b>	{Meritor MFS-14-143A} Wide Track, I-Beam Type, 14,600-lb Capacity
<b>AXLE, REAR, TANDEM:</b>	{Meritor MT-40-14X-4DFR-P} Single Reduction, 0.433"(11mm) Wall Housing Thickness, 40,000- lb Capacity, R Wheel Ends, With Lube Oil Pump Gear Ratio: 4.33
<b>CAB:</b>	Conventional
<b>TIRE, FRONT:</b>	(2) 12R22.5 G661 HSA (GOODYEAR) 484 rev/mile, load range H, 16 ply
<b>TIRE, REAR:</b>	(8) 11R22.5 G622 RSD (GOODYEAR) 497 rev/mile, load range G, 14 ply
<b>SUSPENSION, REAR, AIR, TANDEM:</b>	{Hendrickson HAS-402-55} 55" Axle Spacing; 40,000-lb Capacity, 9.5" Ride Height, With Shock Absorbers Mounted in Standard Location
<b>PAINT:</b>	Cab schematic 100KT Location 1: 9219, Winter White (Std) Chassis schematic N/A



Vehicle Specifications

July 20, 2015

2016 CT660S SBA 6x4 (CF7AA)

<u>Code</u>	<u>Description</u>	<u>F/R Wt</u> (lbs)	<u>Tot Wt</u> (lbs)	<u>List</u> (US DOLLAR)
CF7AA00	Base Chassis, Model CT660S SBA 6x4 with 187.00 Wheelbase, 125.00 CA, and 69.00 Axle to Frame.	9385/6587	15972	\$139,218.02
1570	TOW HOOK, FRONT (2) Frame Mounted	50/-10	40	\$372.38
1652	CROSSMEMBER, REAR Relocated to End of Frame	-21/102	81	\$234.14
1CDH	FRAME RAILS Heat Treated Alloy Steel (120,000 PSI Yield); 12.250" x 3.380" x 0.375" (304.8mm x 85.6mm x 9.5mm); 543.0" (13793mm) Maximum OAL	74/179	253	\$0.00
1LBC	BUMPER, FRONT Multi-piece Stainless Steel	0/0	0	\$0.00
	<u>Includes</u> : FOG LIGHT OPENING (2) and with Rectangular Hole for Step			
1WVS	WHEELBASE RANGE 183" (465cm) Through and Including 228" (580cm)	0/0	0	\$865.38
2ASM	AXLE, FRONT NON-DRIVING {Meritor MFS-14-143A} Wide Track, I-Beam Type, 14,600-lb Capacity	0/0	0	\$1,099.08
3ACP	SUSPENSION, FRONT, SPRING Multileaf, Shackle Type; 16,000-lb Capacity; Less Shock Absorbers	7/0	7	\$16.34
	<u>Includes</u> : SPRING PINS Threaded			
4091	BRAKE SYSTEM, AIR Dual System for Straight Truck Applications	0/0	0	\$0.00
	<u>Includes</u> : BRAKE LINES Color and Size Coded Nylon : DRAIN VALVE Twist-Type : DUST SHIELDS, FRONT BRAKE : DUST SHIELDS, REAR BRAKE : GAUGE, AIR PRESSURE (2) Air 1 and Air 2 Gauges; Located in Instrument Cluster : INVERSION VALVE Bendix SR-1 and Double Check Valve : PARKING BRAKE CONTROL Yellow Knob, Located on Instrument Panel : PARKING BRAKE VALVE For Truck : QUICK RELEASE VALVE Bendix On Rear Axle for Spring Brake Release: 1 for 4x2, 2 for 6x4 : SLACK ADJUSTERS, FRONT Automatic : SLACK ADJUSTERS, REAR Automatic : SWITCH, AUXILIARY Interrupter for Cab Clearance/Marker Lights (Blinks Lights with Headlight Switch in "ON" Position); Instrument Panel Mounted			
	<u>Notes</u> : The following features should be considered when calculating Rear GAWR: Rear Axles; Rear Suspension; Brake System; Brakes, Rear Air Cam; Brake Shoes, Rear; Special Rating, GAWR; Wheels; Tires.			
4193	BRAKES, FRONT, AIR CAM 16.5" x 6", Includes 24 SqIn Long Stroke Brake Chambers	115/0	115	\$0.00
4619	TRAILER CONNECTIONS Four-Wheel, With Hand Control Valve and Tractor Protection Valve, for Straight Truck	2/0	2	\$524.39



Vehicle Specifications

July 20, 2015

2016 CT660S SBA 6x4 (CF7AA)

<u>Code</u>	<u>Description</u>	<u>F/R Wt</u> (lbs)	<u>Tot Wt</u> (lbs)	<u>List</u> (US DOLLAR)
	<u>Includes</u> : INVERSION VALVE Bendix SR-1 and Double Check Valve			
4732	DRAIN VALVE {Berg} Manual; With Pull Chain, for Air Tank	0/0	0	\$0.00
	<u>Includes</u> : DRAIN VALVE Mounted in Wet Tank			
4AZJ	AIR BRAKE ABS {Bendix AntiLock Brake System} Full Vehicle Wheel Control System (4-Channel) With Automatic Traction Control	0/0	0	\$163.04
4EBS	AIR DRYER {Bendix AD-9} With Heater	0/0	0	\$0.00
	<u>Includes</u> : AIR DRYER LOCATION Inside Left Rail, Back of Cab			
4EXU	BRAKE CHAMBERS, REAR AXLE {Bendix EverSure} 30/30 Spring Brake	0/0	0	\$0.00
4EXV	BRAKE CHAMBERS, FRONT AXLE {Bendix} 24 SqIn	0/0	0	\$0.00
4NDB	BRAKES, REAR, AIR CAM S-Cam; 16.5" x 7.0"; Includes 30/30 Sq.In. Long Stroke Brake Chamber and Spring Actuated Parking Brake	0/0	0	\$0.00
4SPM	AIR COMPRESSOR {Bendix BA-921 Head Unload} 15.9 CFM Capacity, Single Cylinder	0/0	0	\$0.00
5710	STEERING COLUMN Tilting and Telescoping	0/0	0	\$0.00
5PTB	STEERING GEAR (2) {Sheppard M-100/M-80} Dual Power	126/-13	113	\$1,047.23
5WBH	STEERING WHEEL {Caterpillar} 2-Spoke, 18" Diam., Dark Neutral, Leather Wrapped	0/0	0	\$0.00
7BJU	EXHAUST SYSTEM Switchback Horizontal Aftertreatment Device, Frame Mounted Right Side Under Cab; Includes Single Vertical Tail Pipe & Guard, Right Side, Cab Mounted	0/0	0	\$0.00
7WAZ	TAIL PIPE (1) Turnback Type, Non-Bright, for Single Exhaust	0/0	0	\$55.04
8000	ELECTRICAL SYSTEM 12-Volt, Standard Equipment	0/0	0	\$0.00
	<u>Includes</u> : BATTERY BOX Aluminum : CIGAR LIGHTER Includes Ash Cup, Center Console Mounted : FUSES, ELECTRICAL SAE Blade-Type : HAZARD SWITCH Integral with Turn Signal Switch : HEADLIGHT DIMMER SWITCH Integral with Turn Signal Lever : HEADLIGHTS (2) Composite with Halogen Projector Beam : HORN, AIR Single, Chrome : HORN, ELECTRIC Single : PARKING LIGHT Integral with Front Turn Signal and Rear Tail Light : READING LIGHT, CAB (2) with Individual Switches; One Above Each Door : STARTER SWITCH Electric, Key Operated : STOP, TURN, TAIL & B/U LIGHTS Dual, Rear, Combination with Reflector : TURN SIGNAL FLASHER : TURN SIGNAL SWITCH Manual Cancelling with Lane Change Feature			



Vehicle Specifications

July 20, 2015

2016 CT660S SBA 6x4 (CF7AA)

<u>Code</u>	<u>Description</u>	<u>F/R Wt</u> (lbs)	<u>Tot Wt</u> (lbs)	<u>List</u> (US DOLLAR)
	: TURN SIGNALS, FRONT Includes Integral Reflectors and Side Marker Lights; Fender Mounted : WINDSHIELD WIPER SWITCH 2-Speed with Wash and Intermittent Feature, Steering Column Mounted : WINDSHIELD WIPERS Single Motor, Electric, Cowl Mounted : WIRING, CHASSIS Color Coded and Continuously Numbered			
8554	TRAILER CONNECTION SOCKET 7-Way; Mounted at Rear of Frame	1/5	6	\$196.19
8653	HORN, AIR Single, Located Under Cab	5/0	5	\$0.00
8718	POWER SOURCE Cigar Type Receptacle without Plug and Cord	0/0	0	\$0.00
8GGN	ALTERNATOR {Bosch LH160} Brush Type, 12 Volt 160 Amp. Capacity, Pad Mount	0/0	0	\$0.00
8HAB	BODY BUILDER WIRING Back of Standard Cab at Left Frame or Under Extended or Crew Cab at Left Frame; Includes Sealed Connectors for Tail/Amber Turn/Marker/ Backup/Accessory Power/Ground and Sealed Connector for Stop/Turn	2/1	3	\$96.75
8MMJ	BATTERY SYSTEM {Caterpillar} (3) 12 Volt 2130CCA Total	0/0	0	\$0.00
8RMD	RADIO AM/FM/WB/Clock/3MM Auxiliary Input, with Multiple Speakers	1/0	1	\$329.67
8RMG	ANTENNA BASE (2) Single Function, (1) for CB and (1) for Entertainment Radio, Without Splitter, Separate Lead-Ins, With CB Antenna Mounted on Left Mirror and AM/FM Antenna Mounted on Right Mirror	0/0	0	\$0.00
8VUK	BATTERY BOX Aluminum With Plastic Cover, 18" Wide, 2, 3, or 4 Battery Capacity, Mounted Right Side Back of Cab	0/0	0	\$0.00
8WCK	POWER SOURCE, TERMINAL TYPE 2-Post	0/0	0	\$0.00
8WEZ	TURN SIGNAL SWITCH Self-Canceling	0/0	0	\$0.00
8WKU	BATTERY DISCONNECT SWITCH 200 Amp; Lever Operated, Locks with Padlock, Battery Box Mounted, Does Not Disconnect Charging Circuits, Disconnects Power to PDC	6/4	10	\$154.98
8WNH	RUNNING LIGHT (2) Daytime	0/0	0	\$0.00
8WXG	STARTING MOTOR {Mitsubishi Electric Automotive America 105P} 12-Volt, with Soft-Start	0/0	0	\$0.00
8WZC	BEACON LIGHTS (2) Cab Mounted, Includes Mounting Brackets, Wiring and Switch on Dash	21/1	22	\$424.73
8XAH	CIRCUIT BREAKERS Manual-Reset (Main Panel) SAE Type III With Trip Indicators, Replaces All Fuses Except For 5-Amp Fuses	0/0	0	\$88.69
9ASE	FRONT END Tilting Composite	0/0	0	\$0.00
	<u>Includes</u> : GRILLE SURROUND Brushed Stainless Steel			
9HAN	INSULATION, UNDER HOOD for Sound Abatement	0/0	0	\$0.00
9HBN	INSULATION, SPLASH PANELS for Sound Abatement	0/0	0	\$0.00



Vehicle Specifications

July 20, 2015

2016 CT660S SBA 6x4 (CF7AA)

<u>Code</u>	<u>Description</u>	<u>F/R Wt</u> (lbs)	<u>Tot Wt</u> (lbs)	<u>List</u> (US DOLLAR)
10060	PAINT SCHEMATIC, PT-1 Single Color, Design 100	0/0	0	\$0.00
10761	PAINT TYPE Base Coat/Clear Coat, 1-2 Tone	0/0	0	\$0.00
10WJM	GCWR RANGE , GCWR Equal to or Less than 66,000-lb, for Transmission Application Validation	0/0	0	\$0.00
11001	CLUTCH Omit Item (Clutch & Control)	-141/0	-141	\$0.00
12KXM	ENGINE, DIESEL {CT 13} EPA 2010, SCR, 370 HP @ 1700 RPM, 1350 lb-ft Torque @ 1000 RPM, 2100 RPM Governed Speed, 370 Peak HP (Max)	0/0	0	\$0.00
12THT	FAN DRIVE {Horton Drivemaster} Direct Drive Type, Two Speed With Residual Torque Device for Disengaged Fan Speed	0/0	0	\$0.00
12UND	FEDERAL EMISSIONS EPA, OBD and GHG Certified for Calendar Year 2015; CT13 Engines	0/0	0	\$8,000.00
12VBT	AIR CLEANER Single Element, Heavy Duty	0/0	0	\$0.00
12WBR	FAN OVERRIDE Manual; With Electric Switch on Instrument Panel, (Fan On With Switch On)	2/0	2	\$28.06
12WCX	HOSE CLAMPS, RADIATOR HOSES {Gates} Shrink Band Type	0/0	0	\$0.00
12WEG	COLD STARTING EQUIPMENT Automatic; With Engine ECM Control	0/0	0	\$0.00
12WTA	FAN DRIVE SPECIAL EFFECTS Fan Cooling Ring with Fan Shroud Effects, Engine Mounted	0/0	0	\$0.00
12WZE	EMISSION COMPLIANCE Federal, Does Not Comply With California Clean Air Idle Regulations	0/0	0	\$0.00
12XAV	RADIATOR Aluminum; Welded, Front to Back Down Flow System, 1429 SqIn, 740 SqIn CAC, 1099 SqIn 3 Core LTR	0/0	0	\$0.00
13CZZ	TRANSMISSION, AUTOMATIC {Caterpillar CX31} 1st Generation Controls; 6 Speed, Includes Oil Level Sensor, with PTO Provision, for ON/OFF Highway	77/15	92	\$20,835.86
	<u>Includes</u> : OIL FILTER, TRANSMISSION Mounted on Transmission : TRANSMISSION OIL PAN Magnet in Oil Pan			
13WCU	OIL COOLER, AUTO TRANSMISSION {Modine} Remote Mounted; For Use With Automatic Transmission Less Retarder	35/0	35	\$895.05
13WLM	TRANSMISSION OIL Synthetic; 63 thru 76 Pints	0/0	0	\$333.79
14862	PDL WARNING BUZZER Power Divider Lock	0/2	2	\$26.88
14899	SUSPENSION AIR CONTROL VALVE Pressure Release Control In Cab	4/4	8	\$146.02
14GVU	AXLE, REAR, TANDEM {Meritor MT-40-14X-4DFR-P} Single Reduction, 0.433"(11mm) Wall Housing Thickness, 40,000-lb Capacity, R Wheel Ends, With Lube Oil Pump . Gear Ratio: 4.33	0/0	0	\$0.00
	<u>Includes</u> : POWER DIVIDER LOCK Air Operated, Cab Control with Indicator Light in Cluster			



Vehicle Specifications

July 20, 2015

2016 CT660S SBA 6x4 (CF7AA)

Code	Description	F/R Wt (lbs)	Tot Wt (lbs)	List (US DOLLAR)
	: REAR AXLE DRAIN PLUG (2) Magnetic, For Tandem Rear Axle			
14UKZ	SUSPENSION, REAR, AIR, TANDEM {Hendrickson HAS-402-55} 55" Axle Spacing; 40,000-lb Capacity, 9.5" Ride Height, With Shock Absorbers Mounted in Standard Location	0/65	65	\$168.56
14WMJ	AXLE, REAR, LUBE {EmGard FE-75W-90} Synthetic Oil; 50 thru 64.99 Pints	0/0	0	\$313.04
15DYP	DEF TANK 9.5 U.S. Gal. 36.0L Capacity, Frame Mounted Outside Left Rail, Under Cab	0/0	0	\$0.00
15LKU	FUEL/WATER SEPARATOR {Racor} Fuel Pre-Filter and Filter Base, Includes Water-In-Fuel Sensor	0/0	0	\$0.00
15SHC	FUEL TANK Non-Polished Aluminum, 24" Diam., 100 U.S. Gal., 378 L Capacity Left Side, Under Cab.	21/17	38	\$237.40
16031	CAB Conventional	0/0	0	\$0.00
	<u>Includes</u>			
	: COAT HOOK, CAB Located on Rear Wall, Behind Passenger Seat			
	: CONSOLE, CENTER Plastic, Driver Convenience with a Cup and Change Holder, Ash Tray and Lower Storage Area			
	: DOME LIGHT, CAB (2) Driver and Passenger Dome Lights with Individual Switches, in Headliner			
	: DOOR CHECK STRAP (2) One Each Door			
	: GLASS, ALL WINDOWS Tinted			
	: GRAB HANDLE, CAB INTERIOR (1) "A" Pillar Mounted, Passenger Side			
	: GRAB HANDLE, EXTERIOR (2) Mounted Behind Driver and Passenger Doors			
	: INTERIOR SHEET METAL Upper Door (Above Window Ledge) Painted Exterior Color			
	: SKIN Riveted			
	: STEP (4) Two Steps Per Door			
16HBA	GAUGE CLUSTER English With English Electronic Speedometer	0/0	0	\$0.00
16HGL	GAUGE, OIL TEMP, REAR AXLE	0/0	0	\$163.40
16JPC	SEAT, DRIVER {National 2000 Model 295} Air Suspension, Intermediate Back, All Vinyl, 2 Arm Rests, Isolator, 7" Adjuster, 1 Chamber Lumbar, 2 Position Front Cushion Adjust, 3 Position Rear Cushion, 2-15 Degree Back Angle Adjust, Vinyl Suspension Cover	0/0	0	\$0.00
16RAC	SEAT, PASSENGER {National 2000 Model 292} Non Suspension, Intermediate Back, All Vinyl, 11 Degree Back Angle Adjustment	31/5	36	\$484.65
16SKV	MIRRORS (2) {Lang Mekra} Aero; Rectangular, Power Both Sides, Thermostatically Controlled Heated Heads, Amber Lens Clearance Light LED, Turn Signals, Black Painted Finish Heads, Brackets & Arms, Breakaway Type, 7.09" x 15.75" & Integral Convex Both Sides, 102" Inside Spacing	0/0	0	\$139.32



Vehicle Specifications

July 20, 2015

2016 CT660S SBA 6x4 (CF7AA)

<u>Code</u>	<u>Description</u>	<u>F/R Wt</u> (lbs)	<u>Tot Wt</u> (lbs)	<u>List</u> (US DOLLAR)
16VRT	HEATER, ENHANCED CIRCULATION {Bergstrom} Control, for Extreme Cold Weather Climates	0/0	0	\$0.00
16VTH	CAB INTERIOR TRIM Premium Level; for Caterpillar, Day Cab  <u>Includes</u> : "A" PILLAR COVER Molded Plastic : CAB INTERIOR TRIM PANELS Vinyl : CONSOLE, OVERHEAD Molded Plastic with Three Storage Pockets; One with Strap for CB Radio Mounting; Two with Netting, Courtesy Lights with Switches : COURTESY LIGHT (2) Driver and Passenger Door Mounted : DOOR TRIM PANELS Vinyl Upper with Power Locks and Windows, Upper and Lower Grab Handles, Both Sides : FLOOR COVERING Rubber, Black : HEADLINER Soft Padded Vinyl : HEATER BOX Metal, Painted Black : INSTRUMENT PANEL TRIM Vinyl : MIRROR, CONVEX, LOOK DOWN Black Finish; 6" x 10-1/4"; Located on Passenger Side : STORAGE POCKET, DOOR (2) Driver and Passenger Door : SUN VISOR (2) Vinyl with Molded Toll Ticket Retainer	0/0	0	\$0.00
16VZA	WINDOW, REAR 52.25" Wide	0/0	0	\$0.00
16WAK	WINDOW, POWER (2) in Left and Right Doors	0/0	0	\$0.00
16WBX	SEAT BELT All Belting Must Be Orange	0/0	0	\$37.73
16WJG	CAB DOOR LOCKS Power	0/0	0	\$0.00
16WKB	AIR CONDITIONER {International Blend-Air} With Integral Heater & Defroster	0/0	0	\$0.00
16WKS	WINDSHIELD Two Piece	1/0	1	\$179.96
16WLD	CAB REAR SUSPENSION {Link Z9079D1} Dual Frame Mounted Cab Rear Air Suspension; Includes Special Crossmember Assembly	0/0	0	\$0.00
16XWD	SUNSHADE, EXTERIOR Aerodynamic, Painted Roof Color; Includes Integral Clearance/Marker Lights	0/0	0	\$0.00
27DPL	WHEELS, FRONT DISC; 22.5" Painted Steel, 5-Hand Hole, 10-Stud (285.75MM BC) Hub Piloted, Flanged Nut, Metric Mount, 9.00 DC Rims; With .500" Thick Disc, Non-Standard Offset and Steel Hubs  <u>Includes</u> : PAINT IDENTITY, FRONT WHEELS White	68/0	68	\$245.10
28DTJ	WHEELS, REAR {Maxion 90541} DUAL DISC; 22.5" Painted Steel, 2 Hand Hole, 10 Stud (285.75MM BC) Hub Piloted, Flanged Nut, Metric Mount, 8.25 DC Rims; With Steel Hubs	0/447	447	\$51.96
29PAR	PAINT IDENTITY, FRONT WHEELS Disc Front Wheels; With Vendor Applied White Powder Coat Paint	0/0	0	\$20.64
29PAS	PAINT IDENTITY, REAR WHEELS Disc Rear Wheels; With Vendor Applied White Powder Coat Paint	0/0	0	\$77.40
29WLA	WHEEL BEARING, FRONT, LUBE {EmGard 50W} Synthetic Oil	0/0	0	\$21.50



Vehicle Specifications

July 20, 2015

2016 CT660S SBA 6x4 (CF7AA)

<u>Code</u>	<u>Description</u>	<u>F/R Wt</u> (lbs)	<u>Tot Wt</u> (lbs)	<u>List</u> (US DOLLAR)
7372138102	(8) TIRE, REAR 11R22.5 G622 RSD (GOODYEAR) 497 rev/ mile, load range G, 14 ply	0/40	40	\$1,470.32
7382158107	(2) TIRE, FRONT 12R22.5 G661 HSA (GOODYEAR) 484 rev/ mile, load range H, 16 ply	38/0	38	\$812.62
<b>Total of Product Features</b>				<b>\$179,575.31</b>
<b>Total Component Weight:</b>		<b>9910/7451</b>	<b>17361</b>	
<b>Total List Price Including Options:</b>				<b>\$179,575.31</b>

The weight calculations included in this proposal are an estimate of future vehicle weight. The actual weight as manufactured may be different from the estimated weight. Neither Caterpillar nor its suppliers shall be liable for any consequences resulting from any differences between the estimated weight of a vehicle and the actual weight.



2016 CT660S SBA 6x4 (CF7AA)  
ENGINE, DIESEL (0012KXM)

ATTACHMENTS: 0016HBA (GAUGE CLUSTER) 0015LKU (FUEL/WATER SEPARATOR) 0012WEG (COLD STARTING EQUIPMENT) 0012THT (FAN DRIVE)

<u>Parameter</u>	<u>Value</u>	<u>UOM</u>
Max Accelerator Vehicle Speed:7902	70	MPH
Vehicle Speed Limiter Override:7911	0, DISABLE FEATURE OR FUNCTION	N/A
VSLO Speed Increment:7912	10	MPH
VSLO Maximum Activation Time:7914	30	MIN
VSLO Time Interval to Reset:7915	8.0	HOURS
VSLO Time Duration Source:7934	1, INTERVAL BASED ON REAL TIME CLOCK	N/A
Progressive Shift Enable:7744	0, DISABLE FEATURE OR FUNCTION	N/A
Low Gear Ratio Break Point:7742	1.265000	N/A
High Gear Ratio Break Point:7743	0.000000000	N/A
Low Gear Engine Speed Limit:7738	1550.0	RPM
High Gear Engine Speed Limit:7739	1600.0	RPM
Low Gear Engine Speed Range:7740	200.0	RPM
High Gear Engine Speed Range:7741	200.0	RPM
Min Gear Ratio for ProShift:7755	0.50	N/A
Gear Down Protection Enable:7714	0, DISABLE FEATURE OR FUNCTION	N/A
Top Gr Minus 2 Light Ld VS Lim:7715	50	MPH
Top Gr Minus 1 Light Ld VS Lim:7716	56	MPH
Top Gr Minus 2 Heavy Ld VS Lim:7735	48	MPH
Top Gr Minus 1 Heavy Ld VS Lim:7736	57	MPH
Driver Reward Enable:7918	0, DISABLE FEATURE OR FUNCTION	N/A
Driver Reward Mode:7930	2, BOTH ACCELERATOR AND CRUISE VEHICLE SPEED LIMIT INCREASE	N/A
Driver Reward Performance Crit:7925	0, FUEL ECONOMY BASED REWARD SYSEM	N/A
Fuel Economy - Expected Level:7921	6.00	MPG
Fuel Economy - Good Level:7920	6.25	MPG
Fuel Economy - Excellent Level:7919	6.40	MPG
% Idle Time - Expected Level:7924	25	%
% Idle Time - Good Level:7923	18	%
% Idle Time - Excellent Level:7922	10	%
Driver Reward Ambient Temp H:7938	150.0	C
Driver Reward Ambient Temp L:7939	-40.0	C
VS Lim Increase - Expected Lvl:7926	0	MPH
VS Lim Increase - Good Lvl:7927	2	MPH
VS Lim Increase - Excel Lvl:7928	4	MPH
VS Lim Decrease - Penalty Lvl:7929	-2	MPH
Idle Engine Speed:8202	600.0	RPM
Idle Speed Adjustment Enable:8215	1, ENABLE FEATURE OR FUNCTION	N/A
Idle Spd Adjust - Max Eng Spd:8212	0.0	RPM
Idle Spd Adjust - Bump Step:8216	5.0	RPM
Idle Spd Adjust Ramp Rate:8211	25	RPM/SEC
Maximum Standstill Eng Speed:7753	2100.0	RPM
Idle Shutdown Mode:7400	0, DISABLE FEATURE OR FUNCTION	N/A
ISD Time w/Park Brk Released:7401	15.0	MIN
ISD Time w/Park Brake Set:7404	5.0	MIN
ISD Latched Driver Override En:7407	0, DISABLE FEATURE OR FUNCTION	N/A
ISD Ambient Temp Override En:7408	0, DISABLE FEATURE OR FUNCTION	N/A
ISD Int Amb Temp Enable:7405	0, DISABLE FEATURE OR FUNCTION	N/A
ISD Max Ambient Temp Override:7402	20.0	C
ISD Int Amb Temp Override:7406	15.0	C
ISD Min Ambient Temp Override:7403	5.0	C
ISD Max Engine Coolant Temp:7412	150.0	C
ISD Min Engine Coolant Temp:7413	16.0	C
ISD Idle Shutdown Max Eng Trq:7409	80	%
Cruise Control Enable:7600	1, ENABLE FEATURE OR FUNCTION	N/A



Electronic Parameters Summary

July 20, 2015

2016 CT660S SBA 6x4 (CF7AA)

CC Max Vehicle Speed:7604	70	MPH
CC Min Vehicle Speed:7603	25.0000	MPH
AESC Control:7500	0, DISABLE FEATURE OR FUNCTION	N/A
AESC In-cab Mode:7502	2, VARIABLE ENGINE SPEED CONTROL SELECTED	N/A
AESC Min Engine Speed:7522	600.0	RPM
AESC Max Engine Speed:7508	1500.0	RPM
AESC Preset Engine Speed 1:7505	800.0	RPM
AESC Preset Engine Speed 2:7506	900.0	RPM
AESC Preset Engine Speed 3:7514	1000.0	RPM
AESC Preset Engine Speed 4:7515	1100.0	RPM
AESC Preset Engine Speed 5:7516	1200.0	RPM
AESC Preset Engine Speed 6:7517	1300.0	RPM
AESC Activate at Preset Speed:7528	0, NO PRESET PRESELECTION	N/A
AESC Ramp Up Rate:7507	100.00	RPM/SEC
AESC Ramp Down Rate:7524	100.00	RPM/SEC
AESC Bump Up/Down Step:7525	25.0	RPM
AESC In-cab Operator Interface:7503	0, NO (OFF) OR DISABLE	N/A
AESC Disable w/ Clutch Pedal:7510	1, ENABLE FEATURE OR FUNCTION	N/A
AESC Disable w/ Brake Pedal:7511	1, ENABLE FEATURE OR FUNCTION	N/A
AESC Accel Pedal Mode:7513	1, AESC OVERRIDDEN BY ACCELERATOR PEDAL	N/A
AESC Max Engine Load:7519	100.0000	%
AESC Control to Engine Load:7530	0, KICK OUT OF AESC ABOVE PROGRAMMED LIMIT	N/A
AESC Max Engine Load Time:7527	8	SEC
AESC Vehicle Speed Limit:7521	5.0000	MPH
AESC Max Mobile Veh Spd:7501	5	MPH
AESC Eng Spd Limit w/VSS Fault:7518	1500	RPM
AESC Force Fan On:9007	0, DISABLE FEATURE OR FUNCTION	N/A
AESC Park Brake Override:7534	1, ENABLE FEATURE OR FUNCTION	N/A
AESC Transfer Case Signal Mode:8910	0, DRIVELINE	N/A
AESC Splitshaft Veh SPD Dsply:9307	0, SPEED SENSOR LOCATED IN WHEEL RIM	N/A
AESC Remote Accel Pedal Enable:7504	0, DISABLE FEATURE OR FUNCTION	N/A
AESC Remote Accel Pedal Switch:8914	0, DISABLE FEATURE OR FUNCTION	N/A
AESC Accel Max Eng Spd Ovr:7520	1900.0	RPM
Rem Accelerator Switch Input:9929	1, SAE J1939 MULTIPLEXED	N/A
Preset Remote AESC Input Type:9932	0, DISCRETE (HARDWIRED) INPUT	N/A
Variable Remote AESC Input:9933	0, DISCRETE (HARDWIRED) INPUT	N/A
Rem Accelerator Position Input:9935	1, SAE J1939 MULTIPLEXED	N/A
Engine Protection Mode:7700	2, TWO WAY SHUTDOWN (OIL PRES, WATER TEMP)	N/A
Powertrain Protection Enable:7722	0, DISABLE FEATURE OR FUNCTION	N/A
Max Torque w/o Vehicle Speed:7712	1350.0000	LB-FT
Highest Gear of Low Range:7718	2	N/A
Highest Gear Rat of Low Range:7745	6.00	N/A
Highest Gear of Int. Range:7748	4	N/A
Highest Gear Rat of Int. Range:7746	4.00	N/A
Highest Gear of High Range:7749	6	N/A
Highest Gear Rat of High Range:7747	2.00	N/A
Max Torque in Low Gear Range:7713	1350.0000	LB-FT
Max Torque in Int. Gear Range:7750	1350.0000	LB-FT
Max Torque in High Gear Range:7751	1350.0000	LB-FT
VSS Anti-Tamper Max Eng Speed:7901	1200.0	RPM
Auxillary Shutdown Input Type:9931	0, DISCRETE (HARDWIRED) INPUT	N/A
Veh Speed Sensor Antitampering:7905	0, DISABLE FEATURE OR FUNCTION	N/A
Veh Overspd Threshold Level 1:7723	75.000000	MPH
Veh Overspd Threshold Level 2:7724	77.000000	MPH
Service Interval Enable	0, DISABLE FEATURE OR FUNCTION	N/A
Fuel Used Service Interval:9501	0	GALLONS
Engine Hour Service Interval:9502	0	HOURS
Veh Distance Service Interval:9503	0	MILES
Service Soon Percent to Notify:9507	90	%



Electronic Parameters Summary

July 20, 2015

**2016 CT660S SBA 6x4 (CF7AA)**

Customer Unit Number:6605	0	N/A
Hard Braking Incident Counter:8904	1, ENABLE FEATURE OR FUNCTION	N/A
Hard Braking Decel Threshold:8905	7.40	MPH/SEC
Vehicle Over-speed Indicator:7754	0, FEATURE OR FUNCTION IS DISABLED	N/A
Customer Password:8700	00000000	N/A

These Electronic Parameters have been successfully finalized



2016 CT660S SBA 6x4 (CF7AA)  
ENGINE/TRANSMISSION MATCHING

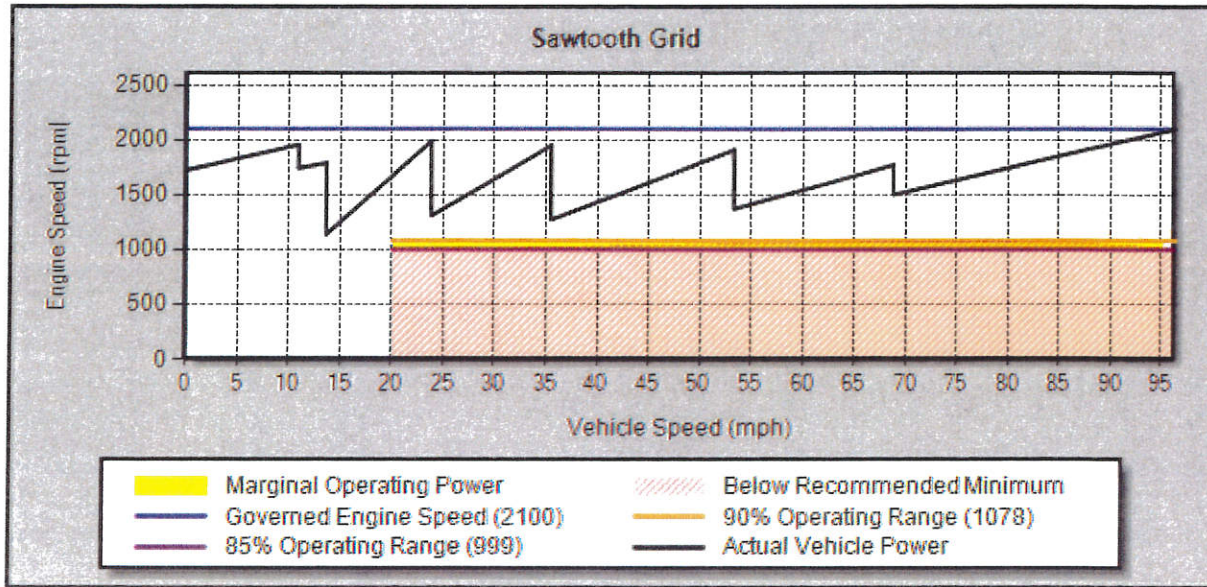

Sawtooth Details

Gear	Trans Ratio	Upshift Power Avail		Govern Power Avail		Peak Power Comparison			Warn Msg
		Veh Spd (MPH)	Eng Spd (RPM)	Veh Spd (MPH)	Eng Spd (RPM)	Gear Step (%)	85% Range (%)	90% Range (%)	
1C	4.40	0.0	1725	10.9	1955	N/A	110	95	
2C	2.33	10.9	1745	13.6	1789	N/A	110	95	
2L	2.33	13.6	1138	23.8	1992	N/A	110	95	
3L	1.53	23.8	1309	35.5	1952	N/A	110	95	
4L	1.00	35.5	1273	53.3	1910	N/A	110	95	
5L	0.72	53.3	1371	68.8	1773	N/A	110	95	
6L	0.61	68.8	1501	96.3	2100	N/A	110	95	

@ - WHEELSLIP CAN OCCUR AT THE GRADE SHOWN. THE VEHICLE IS CAPABLE OF INCREASED GRADEABILITY IF MORE WEIGHT IS PLACED ON THE DRIVE AXLES.



2016 CT660S SBA 6x4 (CF7AA)  
STEADY STATE PERFORMANCE

Performance Results	Gear	Veh Spd (mph)	Eng Spd (rpm)	Fuel Econ (mpg)	Grade (%)	Notes
LEVEL ROAD MAXIMUM SPEED	6L	81.5	1778	4.37	0.00	
HI GEAR SPEED @ RATED RPM	----	----	----	----	----	
55.0 MPH STEADY-STATE	6L	55.0	1199	7.40	1.74	
TYPICAL OPERATING SPEED	6L	70.0	1526	5.60	0.84	- Calculated Grade Ability/Fuel Economy

VEHICLE ORDER CODING ERRORS MAY RESULT IF THE "LEVEL ROAD MAX SPEED" VALUE EXCEEDS THE "HI GEAR SPEED @ RATED RPM" AND IS USED AS THE ENGINE PROGRAMMABLE VEHICLE SPEED LIMIT.

IF THE RESULTS CONTAIN "----", VEHICLE CANNOT ATTAIN THAT SPEED.

IF THE RESULTS CONTAIN "\*\*\*\*\*", THE ENGINE USED DOES NOT HAVE A FUEL MAP. FUEL ECONOMY CANNOT BE PREDICTED.

Recommendations / General Information

IDLE FUEL RATE : 0.80 GALS/HR @ 600.0 RPM  
TORQUE CONVERTER : TC-427 STALL RATIO: 2.32

Fuel Economy Route: Normal Route - City, Suburban, and Highway

Key Fuel Economy Information	City	Suburban	Highway	Notes
MILES PER GALLON	4.91	6.94	6.98	
AVERAGE MPH	19.0	39.8	54.6	
MISSION MINUTES	29.81	52.00	173.36	

IF THE RESULTS CONTAIN "\*\*\*\*\*", THE ENGINE USED DOES NOT HAVE A FUEL MAP. FUEL ECONOMY CANNOT BE PREDICTED.



2016 CT660S SBA 6x4 (CF7AA)  
GRADEABILITY PERFORMANCE

Enroute - Full Throttle Upshift Performance

Gear	Trans Ratio	Veh Spd (mph)	Eng Spd (rpm)	Whl Pwr (hp)	Grade (%)	Warn Notes
1C	4.40	0.0	1725	0.00	51.28	@ STALL
		5.1	1727	237.56	32.46	70% EFF
		6.7	1774	270.24	27.67	80% EFF
		10.9	1955	268.58	16.31	
2C	2.33	10.9	1745	253.59	15.33	
		13.6	1789	277.90	13.26	
2L	2.33	13.6	1138	266.61	12.67	
		23.8	1992	305.23	7.83	
3L	1.53	23.8	1309	301.08	7.71	
		35.5	1952	314.38	4.89	
4L	1.00	35.5	1273	298.46	4.58	
		53.3	1910	326.24	2.55	
5L	0.72	53.3	1371	304.70	2.27	
		68.8	1773	332.57	1.10	
		69.9	1800	333.23	1.00	
		74.1	1907	318.14	0.50	
6L	0.61	77.8	2004	294.85	0.00	LEVEL ROAD
		67.8	1478	313.32	1.00	
		68.8	1501	315.22	0.92	
		74.8	1631	324.47	0.50	
		81.6	1779	330.59	0.00	LEVEL ROAD
		96.3	2100	262.21	-1.69	RATED RPM

STARTING / TOP GEAR PERFORMANCE

Gear	Trans Ratio	Veh Spd (mph)	Eng Spd (rpm)	Whl Pwr (hp)	Grade (%)	Warn Notes
1C	4.40	0.0		0.00	51.28	@ STALL
		6.7		270.24	27.67	80% EFF - Calculated Start Ability

@ - WHEELSLIP CAN OCCUR AT THE GRADE SHOWN. THE VEHICLE IS CAPABLE OF INCREASED GRADEABILITY IF MORE WEIGHT IS PLACED ON THE DRIVE AXLES.

THE TRANSMISSION WAS SIMULATED IN PERFORMANCE OPERATING MODE.



2016 CT660S SBA 6x4 (CF7AA)  
ACCELERATION PERFORMANCE RESULTS

Acceleration Performance Grid

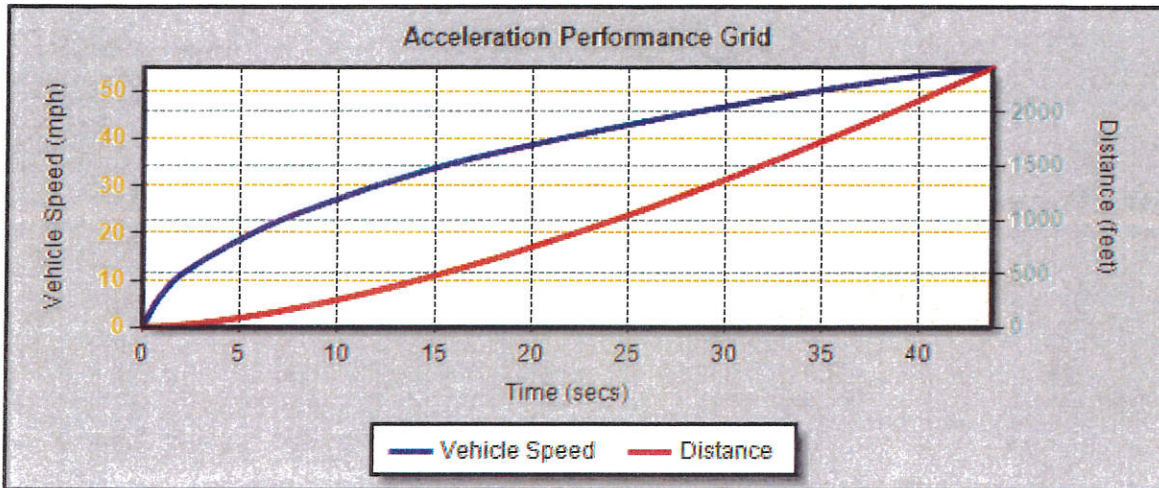

Acceleration Performance: TIME TO ACCELERATE ON A GRADE TO 55.0 (MPH) IS 43.84 (SECS)

Acceleration Performance Details

Gear	Time (secs)	Distance (feet)	Speed (mph)	Notes
1C	0.14	0.1	1.0	
	0.26	0.4	2.0	
	0.38	0.8	3.0	
	0.51	1.5	4.0	
	0.65	2.4	5.0	
	0.81	3.7	6.0	
	1.00	5.4	7.0	
	1.20	7.7	8.0	
	1.42	10.5	9.0	
	1.67	14.0	10.0	
2C	1.93	17.9	10.9	
	2.28	23.7	11.9	
	2.63	30.1	12.9	
2L	2.89	35.2	13.6	
	3.30	43.7	14.6	
	3.72	52.9	15.6	
	4.14	62.9	16.6	
	4.58	73.9	17.6	
	5.04	86.0	18.6	
	5.51	99.3	19.6	
	6.00	113.8	20.6	
3L	6.52	129.7	21.6	
	7.06	147.5	22.6	
	7.67	168.0	23.6	
	7.80	172.7	23.8	
	8.45	195.5	24.8	
	9.10	220.0	25.8	
	9.78	246.0	26.8	
	10.47	273.8	27.8	
	11.19	303.4	28.8	
	11.92	335.0	29.8	
	12.68	368.6	30.8	



2016 CT660S SBA 6x4 (CF7AA)

Gear	Time (secs)	Distance (feet)	Speed (mph)	Notes
4L	13.45	404.4	31.8	
	14.26	442.6	32.8	
	15.11	484.0	33.8	
	16.01	529.6	34.8	
	16.68	563.6	35.5	
	17.72	618.9	36.5	
	18.79	676.7	37.5	
	19.88	737.4	38.5	
	20.99	801.1	39.5	
	22.13	868.1	40.5	
	23.30	938.4	41.5	
	24.50	1012.2	42.5	
	25.73	1089.7	43.5	
	26.99	1171.2	44.5	
	28.29	1256.9	45.5	
	29.63	1347.0	46.5	
	5L	31.00	1441.8	47.5
32.42		1541.7	48.5	
33.89		1647.2	49.5	
35.41		1758.9	50.5	
37.02		1878.9	51.5	
38.73		2009.2	52.5	
40.11		2116.3	53.3	
42.22		2282.8	54.3	
43.84		2412.8	55.0	



2016 CT660S SBA 6x4 (CF7AA)
REQUIRED TCAPE INFORMATION

TCAPE Factors For Vehicle

Table with 2 columns: Factor Name and Value. Includes items like Selected Rear Axle Gear Ratio(s), Vehicle Vocation, Road Surface Type, etc.

Components

Table with 2 columns: Component ID and Description. Lists various vehicle parts like AXLE, AIR COMPRESSOR, STEERING GEAR, etc.

TCAPE HAS BEEN DESIGNED TO GIVE ECONOMY AND PERFORMANCE PREDICTIONS WHICH HAVE BEEN SHOWN TO BE TYPICAL FOR MOST OPERATIONS. HOWEVER, DUE TO OPERATING CONDITIONS, DRIVER INFLUENCES, AND OTHER FACTORS, YOUR RESULTS MAY VARY FROM THOSE PREDICTED.

NEITHER CATERPILLAR NOR ITS SUPPLIERS SHALL BE LIABLE FOR ANY LOSS OF PROFITS, LOSS OF USE, INTERRUPTION OF BUSINESS OR INDIRECT, SPECIAL, INCIDENTAL OR CONSEQUENTIAL DAMAGES OF ANY KIND THAT ARE INCURRED BY DEALER OR BY DEALER'S CUSTOMERS AS A RESULT OF RELIANCE ON TCAPE, WHETHER THE CLAIM IS IN CONTRACT, TORT (INCLUDING NEGLIGENCE), STRICT LIABILITY OR OTHERWISE.



**2016 CT660S SBA 6x4 (CF7AA)**

Series: CAT  
 Model: CF7AA  
 Description: CT660S SBA 6x4  
 Model Year: 2016

**Calculation Factors**

Wheelbase: 187  
 Front Axle: 0002ASM  
 Description: AXLE, FRONT NON-DRIVING, {Meritor MFS-14-143A} Wide Track, I-Beam Type, 14,600-lb Capacity  
 Front Wheel: 0027DPL  
 Description: WHEELS, FRONT, DISC; 22.5" Painted Steel, 5-Hand Hole, 10-Stud (285.75MM BC) Hub Piloted, Flanged Nut, Metric Mount, 9.00 DC Rims; With .500" Thick Disc, Non-Standard Offset and Steel Hubs  
 Front Tire: 07382158107  
 Description: TIRES, 12R22.5 G661 HSA (GOODYEAR) 484 rev/mile, load range H, 16 ply  
 Steering Gear: 0005PTB  
 Description: STEERING GEAR, (2) {Sheppard M-100/M-80} Dual Power

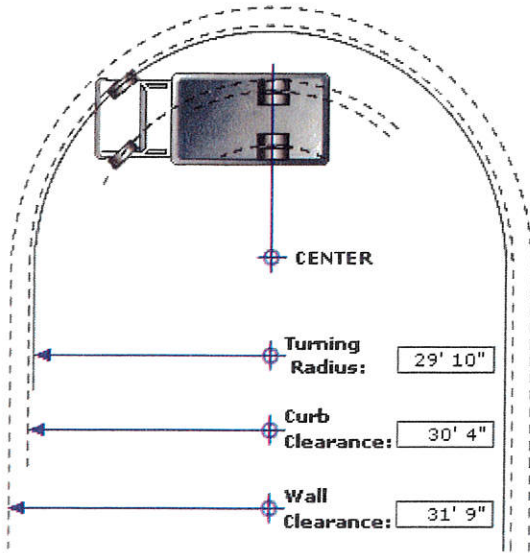

**Turning Radius Statistics**

General Information

Inside Turn Angle: 40 Degrees  
 Radial Overhang: 23

Axle Information

KingPin Inclination: 6.25 Degrees  
 KingPin Center: 71.5

**Turning Radius - Curb View**

C - Curb Contact Length: 16.16  
 CI - Curb Clearance Increment: 6.16  
 CR - Curb Clearance Radius: 30'4"  
 CH - Curb Height: 6"  
 TR - Turning Radius: 29'10"  
 TW - Tire Width: 11.60

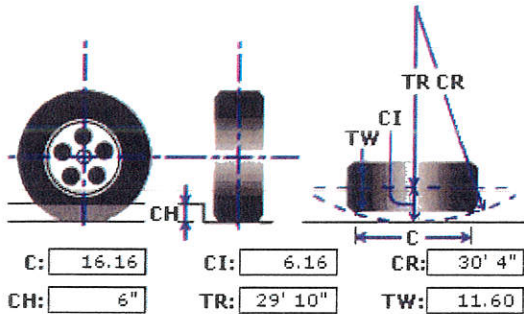

\* All Measurements are in inches, unless otherwise specified.



**2016 CT660S SBA 6x4 (CF7AA)**

This information is based on engineering information available at this time. Actual figures may vary. Neither Caterpillar nor its suppliers can accept liability for consequences due to this variance.



**TRUCK BODIES & EQUIPMENT INTERNATIONAL, Inc.**  
 Ox Bodies | Crysteel | DuraClass | Rugby | J-Craft | Hardee

TBEI - Ox Bodies  
 719 Columbus Street East  
 PO Box 886  
 Fayette AL 35555  
 800-844-2519

**Taken By:** Robert Fowler

# Quote Response Form

**End User:** HIDALGO COUNTY DRA  
**Customer:** 104731  
 Mark Brunnemann  
 HOLT TRUCK CENTERS  
 1320 SOUTH 25TH STREET  
 EDINBURG TX 78539  
 USA

**Phone:** 956-289-7636  
**Fax:** 956-383-6819

Estimate	Terms	Quote Date	Expiration Date	Salesperson	Customer Currency
FA00067213	Net 30 Days	7/20/2015		HOWARD, CHIP	USD

UM	Quantity	Item	Unit Price	Extended Price
EA	1.000	MV851500-1415YD-63130-56/42/50STR-S	9,976.11	9,976.11

Yardage 14/15

Body: Maverick  
 Body: 15' MAVERICK  
 Hoist Model: 1248910-63130  
 Frame Style: 2x8 RT w/1.5x3 RT xmem on 12 CL (framele  
 Rear Style: Straight  
 Front Exhaust Notch: No  
 Front Height: 56"  
 Side Height Front: 42" 10 Gauge  
 Side Height Rear: 42"  
 Rear Height: 50" 7 Gauge  
 Front Material: 10 Gauge  
 Floor Material: 7 Gauge  
 Cabshield Style: Standard  
 Cabshield Projection: 24"  
 Cabshield Width: 85"  
 Tarp Style: Electric - Mountain Tarp  
 Tailgate Type: Standard  
 Sealed Tailgate: No  
 Coal Chute: None  
 Tailgate Operation: Air  
 Tailgate Bracing Style: 1 Horizontal (TG height 37" to 54")  
 Horizontal Side Brace: No  
 Side Top Rail Style: Standard 4x4 11 GA  
 Tread Plate Aluminum Bottom Rail: No  
 Polished Aluminum Insulation Side/Front : No  
 Dump Assist Vibrator: None  
 Dump Apron: Standard 1/4" Plate - 10"  
 Side Light Cutouts: Lower Front/Rear Clearance  
 Cabshield Cutouts: 1 Set  
 Metro Light Cutouts: 1 set  
 Dirt Shedding Angle: No  
 Board Holder Height: 8"  
 ID: 85"  
 Cover Bottom Rail with Alum: No  
 \*\*Cab Height\*\*To be Verified: Not Available  
 \*\*Paint\*\*To be Verified: Stock Ox Color



**TRUCK BODIES & EQUIPMENT INTERNATIONAL, Inc.**  
 Ox Bodies | Crysteel | DuraClass | Rugby | J-Craft | Hardee

TBEI - Ox Bodies  
 719 Columbus Street East  
 PO Box 886  
 Fayette AL 35555  
 800-844-2519

**Taken By:** Robert Fowler

# Quote Response Form

**End User:** HIDALGO COUNTY DRA  
**Customer:** 104731  
 Mark Brunnemann  
 HOLT TRUCK CENTERS  
 1320 SOUTH 25TH STREET  
 EDINBURG TX 78539  
 USA

**Phone:** 956-289-7636  
**Fax:** 956-383-6819

Estimate	Terms	Quote Date	Expiration Date	Salesperson	Customer Currency
FA00067213	Net 30 Days	7/20/2015		HOWARD, CHIP	USD

UM	Quantity	Item	Unit Price	Extended Price
----	----------	------	------------	----------------

Truck: Truck  
 Truck: Installed  
 Side Boards: 1248918-Wood 8" - Up to 17' body  
 Hydraulic Tank: 1250596-Pyramid Flat Bottom Standard  
 Rear Hinge: Standard - Removable Pin  
 Hoist: 1248910-63130  
 Cab Controls: Man. Transmission: 1248922-AS PTO/CS Pmp/Man Trs/EI MT Tarp  
 Pump - Manual Transmission: 1249977-CS/Man/Pump C102-D2.5-3 D/MT CCW  
 PTO - Manual Transmission: 1265632-Manual Transmission, Double Gear  
 Mud Flaps: 1250015- 30" Standard Mud Flaps w/GG  
 Backup Alarm: 1248915-Back-Up Alarm  
 Side Light Quantity: Lower Front Amber / Rear Clearance Red  
 Cab Shield Light Quantity: 1 set Amber  
 Metro Light Quantity: 1 set Red

EA	1.000	1249365	TARP ELEC MT MESH N/FL AL 10-16 IN:	1,116.00	1,116.00
EA	1.000	1250302	HITCH 22" 45TON W/GLADS 7-PIN INST.	1,100.00	1,100.00

\*\*\*\*\*AUTO TRANS - ADD \$1155.00  
 REQUIRED CT: 120"-126"

<b>Gross Sales:</b>	13,027.00
<b>Total Discounts:</b>	834.89
<b>Sale Amount:</b>	12,192.11
<b>Freight:</b>	1,800.00
<b>Sales Tax:</b>	0.00
<b>FET Charges:</b>	0.00
<b>Total Amount:</b>	13,992.11

**AI -51136**

**9.**

**DRAINAGE DISTRICT**

Meeting Date: 09/01/2015

Submitted By: Sylvia Sanchez, DRAINAGE  
DISTRICT

Department: DRAINAGE DISTRICT

---

Information

CAPTION

2012 Bond Referendum Project

A. Approval of offer letter of acceptance and closing documents as it relates to parcel 8, lot 35, Seminole Valley Subdivision Alamo.

B. Approval of manual check to be issued for the completion of the acquisition transaction.

BACKGROUND

---

Fiscal Impact

Attachments

*No file(s) attached.*

---

**Form Review**

<b>Inbox</b>	<b>Reviewed By</b>	<b>Date</b>
Budget & Management	Veronica Ortiz	08/28/2015 02:14 PM
Final Approval	Monica Badillo	08/28/2015 04:56 PM
Form Started By: Sylvia Sanchez		Started On: 08/28/2015 01:40 PM
Final Approval Date: 08/28/2015		

**AI -51091**

**10.**

**DRAINAGE DISTRICT**

Meeting Date: 09/01/2015

Submitted For: Jaime Salazar

Submitted By: Jaime Salazar, DRAINAGE  
DISTRICT

Department: DRAINAGE DISTRICT

---

Information

CAPTION

**2013 BOND SERIES**

A.) Requesting approval of final negotiated Professional Agreement with Javier Hinojosa Engineering for the provision of Engineering Services as it relates to Pct. 2 - PSJA Lateral Drain Ditch. Approved for negotiations by HCDD1 Board of Directors on April 28, 2015.

B.) Pursuant to the Boards approval of Professional Agreement with Javier Hinojosa Engineering requesting approval of Work Authorization No. 1 in the amount of \$135,000.00 for Engineering Services as it relates to Pct. 2 - PSJA Lateral Drain Ditch.

C.) Pursuant to the Boards approval of Professional Agreement with Javier Hinojosa Engineering; requesting approval of Work Authorization No. 2 in the amount of \$36,000 for Survey Services as it relates to Pct. 2 - PSJA Lateral Drain Ditch.

BACKGROUND

---

Fiscal Impact

Attachments

*No file(s) attached.*

---

**Form Review**

<b>Inbox</b>	<b>Reviewed By</b>	<b>Date</b>
Budget & Management	Veronica Ortiz	08/27/2015 03:36 PM
Final Approval	Monica Badillo	08/28/2015 04:56 PM
Form Started By: Jaime Salazar		Started On: 08/27/2015 11:47 AM
Final Approval Date: 08/28/2015		

**AI -51139**

**11.**

**DRAINAGE DISTRICT**

Meeting Date: 09/01/2015

Submitted For: Jaime Salazar

Submitted By: Jaime Salazar, DRAINAGE  
DISTRICT

Department: DRAINAGE DISTRICT

---

Information

CAPTION

**2013 BOND SERIES**

Requesting approval of Notice to Suspend Work for Construction Contract No. HCDD1-14-028-10-28 "Drain Control Structures - Monte Cristo & Weslaco North Lateral". Contractor: M-5 Texas Enterprises, LLC.

BACKGROUND

---

Fiscal Impact

Attachments

NTS

---

**Form Review**

<b>Inbox</b>	<b>Reviewed By</b>	<b>Date</b>
Budget & Management	Veronica Ortiz	08/28/2015 04:23 PM
Final Approval	Monica Badillo	08/28/2015 04:56 PM
Form Started By: Jaime Salazar		Started On: 08/28/2015 02:38 PM
Final Approval Date: 08/28/2015		



<b>NOTICE TO SUSPEND, WORK ORDER</b>		OWNER: Hidalgo County Drainage District No. 1
		PROJECT NAME: Drain Control Structures Monte Cristo & Weslaco North
		PROJECT: HCDD1- 14-028-10-28
ORDER NUMBER:	DATE ISSUED:	NAME AND ADDRESS OF CONTRACTOR: M-5 Texas Enterprises, LLC 2107 Reginald Dr. Weslaco, Texas 78596
1	June 16, 2015	

**THIS IS YOUR NOTICE TO SUSPEND, WORK ON THE CONTRACT AS NOTED.**

**SUSPENSION OF WORK**

You are to suspend work for the following reason(s): Change in project design.

Effective close of business:

Type of Suspension  Total  Partial

No Charge will be made against contract time for period of suspension.

Full count of contract time will continue.

An equitable adjustment of contract time will be made for period of partial suspension upon resumption work.

The Contractor shall, effective immediately, cease to issue any further orders and/or subcontracts for materials or services of this Contract. The Contractor shall immediately comply with this order and take all reasonable steps to minimize the incurrence of cost allocable to the work covered by this during the period of work stoppage.

**DO NOT RESUME WORK UNTIL YOU ARE NOTIFIED TO DO SO IN WRITING**

Zimbra

claudette.guerrero@hcdd1.org

---

**Re: Construction Contract No. HCDD1-14-028-10-28**

---

**From :** Raul Sesin <raul.sesin@hcdd1.org> Fri, Aug 28, 2015 02:04 PM  
**Subject :** Re: Construction Contract No. HCDD1-14-028-10-28  1 attachment  
**To :** Claudette Guerrero <claudette.guerrero@hcdd1.org>  
**Cc :** Jaime Salazar <jaime.salazar@hcdd1.org>, Lora Briones <lora.briones@hcdd1.org>

Jaime I told you that the delay was because of the gate but I was wrong. I went back and looked at my notes and the delay is because the design plans needed to be updated and the proposed gate would not work as proposed. It's no fault of the contractor. We had a meeting with the design engineer this morning and we are making additional changes that may delete the gate

Please prepare the NTS with the proper explanation. Again, it was my fault and I apologize for the confusion.

Any questions let me know.

Thank you.

Raul E. Sesin, PE, CFM  
Sent from my iPhone

On Aug 28, 2015, at 1:59 PM, Claudette Guerrero <[claudette.guerrero@hcdd1.org](mailto:claudette.guerrero@hcdd1.org)> wrote:

Jaime,

As requested, attached please find the NTS form for the project noted above. We request your assistance in providing support documentation regarding the lead time on the sluice gates. I will contact Monica Badillo to see if we can include the form for the Board meeting of 09-01-15.

Respectfully,

<Claudette Signature.fw.png>

---

**From:** "Jaime Salazar" <[jaime.salazar@hcdd1.org](mailto:jaime.salazar@hcdd1.org)>  
**To:** "Claudette Guerrero" <[claudette.guerrero@hcdd1.org](mailto:claudette.guerrero@hcdd1.org)>  
**Cc:** "Lora Briones" <[lora.briones@hcdd1.org](mailto:lora.briones@hcdd1.org)>  
**Sent:** Wednesday, August 26, 2015 11:25:13 AM  
**Subject:** Construction Contract No. HCDD1-14-028-10-28

<NTS 1\_HCDD1-14-028-1028\_CS Monte Cristo & Weslaco North\_BOD 09-01-15.pdf>



Claudette Guerrero  
Accountant - Funds  
Hidalgo County Drainage District No. 1  
902 N. Doolittle  
Edinburg, TX 78542  
Off: 956(292-7080 ext. 5804  
Fax: 956(292-7089  
claudette.guerrero@hcd1.org

**Claudette Signature.fw.png**  
136 KB

---

**AI -51154**

**12.**

**DRAINAGE DISTRICT**

Meeting Date: 09/01/2015

Submitted By: Claudette Guerrero,  
DRAINAGE DISTRICT

Department: DRAINAGE DISTRICT

---

Information

CAPTION

A. Request acceptance and approval by the Hidalgo County Drainage District No. 1 Board of Directors of an "Order" authorizing the Purchase of certain personal property (as described in attachments herein) from Hidalgo County Pct.3 for the agreed upon book value.

B. Request approval of a Budget Amendment from District's un-reserve General Fund in the amount of \$220,393.94 for the purchase of equipment from Hidalgo County Pct.3.

BACKGROUND

---

Fiscal Impact

Attachments

County AI#50996 Pct.3 Equipment Sale  
order  
purchasing valuations

---

**Form Review**

<b>Inbox</b>	<b>Reviewed By</b>	<b>Date</b>
Final Approval	Monica Badillo	08/28/2015 04:56 PM
Form Started By: Claudette Guerrero		Started On: 08/28/2015 03:49 PM
Final Approval Date: 08/28/2015		

AI-50996

Purchasing Department

CC - REGULAR

**Meeting Date:** 09/15/2015

**Submitted For:** Marty Salazar, PURCHASING DEPT.

**Submitted By:** Gabriel Navarro, PURCHASING DEPT.

**Department:** PURCHASING DEPT.

---

**Information**

**CAPTION**

A. Pursuant to Texas Local Government Code, 263.151, discussion and approval to declare as "surplus" as detailed in Exhibit "A" including establishing of a total fair market value in the amount of \$

B. Acceptance and approval by Hidalgo County Commissioners Court evidenced by an "ORDER" authorizing the sale of certain personal property (as described in attachments herein) to Hidalgo County Drainage District No. 1 for the amount approved as the fair market value.

C. Requesting authority to remove said assets listed on Exhibit "A" (attached hereto) from the Hidalgo County inventory list after finalizing the sale of equipment to Drainage District #1.

**BACKGROUND**

---

**Fiscal Impact**

**FISCAL YEAR:**

**ACCT. #:**

**FUNDS AVAILABLE Y/N?:**

**MATCHING FUNDS Y/N?:**

**BUDGETARY IMPACT:**

Fiscal impact to be indentified through DBM. However, the result should be revenue to the county.

---

**Attachments**

*No file(s) attached.*

---

**Form Review**

**Inbox**

**Reviewed By**

**Date**

Gabriel Navarro

08/20/2015 09:29 AM

Form Started By: Gabriel Navarro

Started On: 08/20/2015 09:29 AM

ORDER NO. \_\_\_\_\_

AN ORDER OF HIDALGO COUNTY DRAINAGE DISTRICT NO. 1 AUTHORIZING THE PURCHASE OF THE EQUIPMENT FROM THE COUNTY OF HIDALGO AND APPROVING OTHER MATTERS INCIDENT THERETO.

WHEREAS, THE COUNTY OF HIDALGO (the “County”) and HIDALGO COUNTY DRAINAGE DISTRICT NO. 1 (the “District”) have previously entered into various inter-local agreements for the purpose of undertaking joint improvement to and maintenance of the County’s storm drainage facilities; and

WHEREAS, the County desires to sell certain equipment and machinery which is listed in Exhibit “A” attached hereto to the District for its use in further improving and maintaining the County’s storm drainage facilities in the District; NOW THEREFORE,

BE IT RESOLVED:

## ARTICLE I

### **APPROVAL; DESCRIPTION; PURCHASE PRICE; OTHER TERMS**

- 1.1. Approval. The purchase of the equipment is hereby approved.
- 1.2. Description. The equipment is described in Exhibit “A” attached hereto.
- 1.3. Amount, Purpose, and Authorization. The purchase price for the Equipment is the amount of ONE HUNDRED NINETY ONE THOUSAND NINE HUNDRED TWENTY-THREE AND 02/100 DOLLARS (\$191,923.02) payable in cash upon delivery.
- 1.4. Purchase Rights. The District shall be entitled to full title and all ownership interests in the Equipment.
- 1.5. Consummation of Purchase. At closing or delivery, the County shall deliver to District such deeds, titles, termination statements, bills of sale and other documents and instruments as District shall reasonably require to evidence the transfer of all right, title and interest of the County in such Equipment to District free and clear of all liens and encumbrances created by or arising, directly or indirectly, through the County.

## ARTICLE II

### COVENANTS OF THE DISTRICT

2.1 Use of Equipment. The District shall use the Equipment in a careful and proper manner, in compliance with all applicable laws and regulations, including the tax exempt Treasury Regulations and will not dispose of the Equipment without issuance of an opinion by the District's bond counsel to the effect that the disposition will not affect the District's or the County's designation of its debt obligations a tax-exempt.

2.2 Warranties. Except for representations, warranties and service contracts relating to the Equipment made or entered into by the manufacturers or suppliers of the Equipment, all of which are hereby assigned to the District, the County has made and makes no representation or warranty, express or implied, and assumes no obligation with respect to the title, merchantability, condition, quality or fitness of the Equipment described in Schedule for any particular purpose or the conformity of the Equipment to specifications or purchase order, its design, delivery, installation or operation. All claims or actions on any warranty so assigned to the County shall be made or prosecuted by the District, at its sole expense.

2.3 Inspection, Acceptance and Written Notice of Defects. Immediately, or as soon as practicable to provide time for testing, upon receipt and installation of the Equipment, the District shall inspect the Equipment. Unless the District gives the County written notice of each defect or other proper objection to the Equipment before the execution of the Acceptance Certificate, it shall be conclusively presumed, as between the County and the District, that the District has fully inspected and acknowledged that the Equipment is in good condition and repair, has been properly installed and is performing satisfactorily, and that the District is satisfied with and has accepted the Equipment in such good condition and repair.

## ARTICLE III

### MISCELLANEOUS

3.1 Further Proceedings. The Chairman of the Board and other appropriate officials of the District are hereby authorized and directed to do any and all things necessary and/or convenient to carry out the terms of this Agreement.

3.2 Severability. If any section, paragraph, clause or provision of this Agreement shall for any reason be held to be invalid or unenforceable, the invalidity or unenforceability of such section, paragraph, clause or provision shall not affect any of the remaining provisions of this Agreement.

3.3 Open Meeting. It is hereby found, determined and declared that a sufficient written notice of the date, hour, place and subject of the meeting of the District's governing board at which this Order was adopted was posted at a place convenient and readily accessible at

all times to the general public at the official meeting place of the District for the time required by law preceding this meeting, as required by the Texas Open Meetings Law, Chapter 551, Texas Government Code, as amended, and that this meeting was open to the public as required by law at all times during which this Order and the subject matter thereof were discussed, considered and formally acted upon. The District's governing board further ratifies, approves and confirms such written notice and the contents and posting thereof.

3.4. Repealer. All orders and resolutions or parts thereof, inconsistent herewith are hereby repealed to the extent of such inconsistency

PASSED AND APPROVED ON \_\_\_\_\_.

HIDALGO COUNTY DRAINAGE DISTRICT NO. 1

\_\_\_\_\_  
Ramon Garcia, Chairman of the Board

ATTEST:

\_\_\_\_\_  
County Clerk

**Exhibit A**  
**Equipment Description**

HIDALGO COUNTY PURCHASING DEPARTMENT FIXED ASSET DIVISION  
PCT. 3 DRAINAGE EQUIPMENT FAIR MARKET VALUE

Heavy Equipment	Co. Asset Tag #	Hist. Cost	As of 08/31/15 Current Book Value	Google Search **Based on Machine Hrs MACHINERY TRADER.COM	Google Search **Based on Machine Hrs CONSTRUCTION EQUIPMENT GUIDE.COM	Company Quotes **Estimated Value DOGGETT JOHN DEERE
2009 JOHN DEER EXCAVATOR 200D	48906	202,888.52	81,155.41	118,000.00	125,000.00	75,000.00
BOOM W/ARM CYCL & PLUMBING 200D	49059	24,840.31	3,548.62	-	-	22,500.00
ARM W/BUCKET CYL & LINKAGE 200D	49060	14,206.62	2,029.52	-	-	-
BUCKET 48" HD 200D	49061	7,418.07	1,059.72	-	-	-
2009 JOHN DEERE DOZER 750J	48907	260,324.38	104,129.75	144,800.00	125,000.00	70,000.00
<b>Total</b>		<b>509,677.90</b>	<b>191,923.02</b>	<b>262,800.00</b>	<b>250,000.00</b>	<b>167,500.00</b>

**Comparing the values between each company and the Book Values we can safely set the fair market for the aforementioned items at \$ 262,800.00**

**Total FMV for Pct 3 Equipment**

**\$ 262,800.00**